

LEDCL15-150ACCW

LED INDUSTRIAL CANOPY LIGHTS

This 150 W LED Canopy light is a direct replacement for the 400W sodium & metal halide troffer light that is commonly used in service stations, under canopies, truck interchanges and in foodgrade production areas.

With superior IP66 weather proof rating, Cree LED chips, Meanwell drivers, and full surge protection it means this is an extremely robust and reliable luminaire.

Luminaire comes with options for mounting systems for easy installation.

Onboard 1-10V motion sensor is also an option for this luminaire.



TECHNICAL SPECIFICATIONS

Fixture/Part No.	LEDCL15-150ACCW
Total Power	165W
LED Power	150W
LED Lumens	14,000
Fixture Lumens	12,000
LED Source	70 x Cree XP-E LEDs
LED Lighting Efficiency	80lm/W
Colour Temperature	6000K (3000K & 4500K on special order)
Colour Rendering(Ra)	>80
Luminous Uniformity	>0.6
IP Rating	IP66
Life Span	>50,000 hours
Eco-friendly	No UV, IR, Lead or Mercury
Operation Temperature	-30°C to 50°C
Weight	10.5kg
Beam Angle	90° Standard (60° & 120° on special order)
Size	343x343x145mm
Dimmable	No (1-10V dimming on special order)
Power factor	≥0.97
Input Voltage Range	90-295 V AC (47-63Hz)
Power Efficiency	>90%

Available with polycarbonate lens

SUITABLE APPLICATIONS INCLUDE (& not limited to):

- Petrol Stations
- Sports Stadiums
- Food Production Areas
- Car Wash Areas
- Truck Interchange Areas
- Under Canopy Areas

SDOC is available on our website



DIMENSIONS

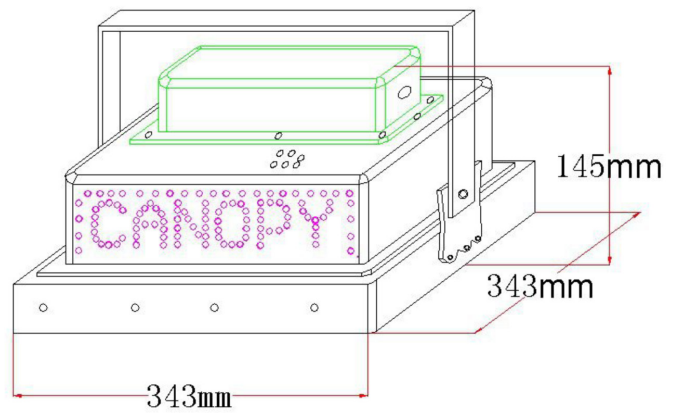
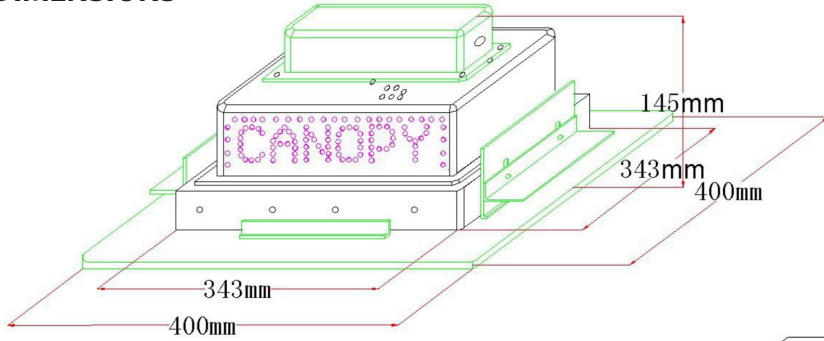

Recommended cutout size: 375x375 for both recess mounting frames.

DISTRIBUTION CURVES

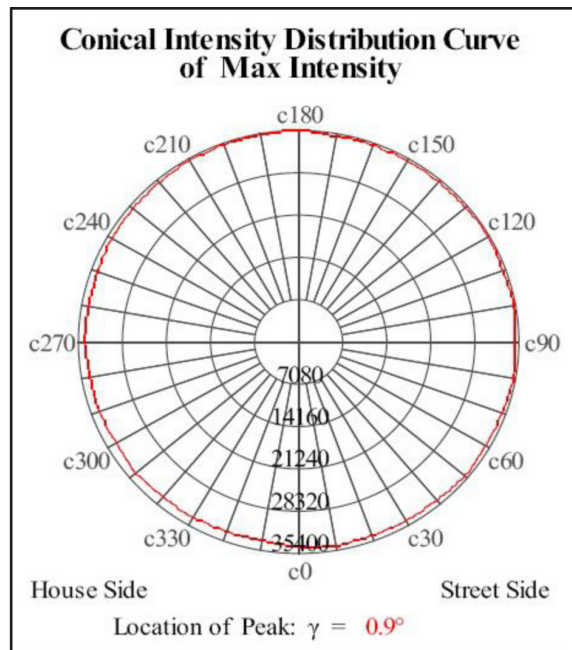
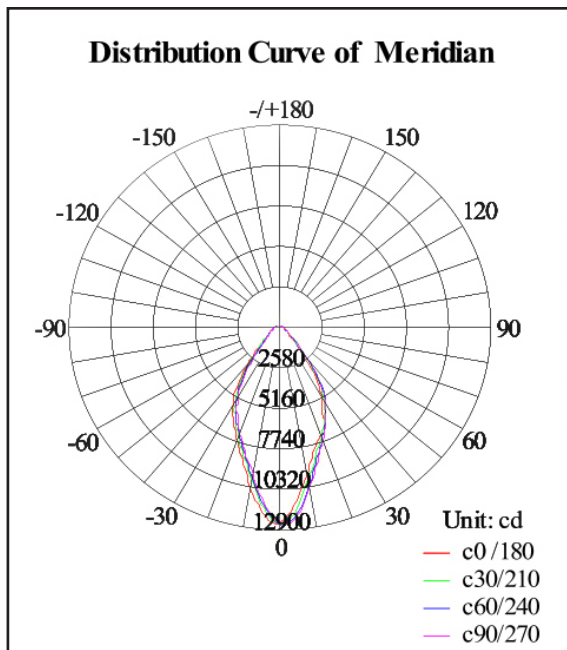

RANGE

Our model range includes:

- Standard 150W Canopy light, non-dimmable
- Onboard Motion Sensor 150W Canopy Light (special order)

Optional Extras include:

- With Recess Mounting Frame, 400mm x 400mm
- With Recess Mounting Frame, 585mm x 585mm
- Mounting bracket for mounting surface